

# LAGRANGE BELT BANDITS

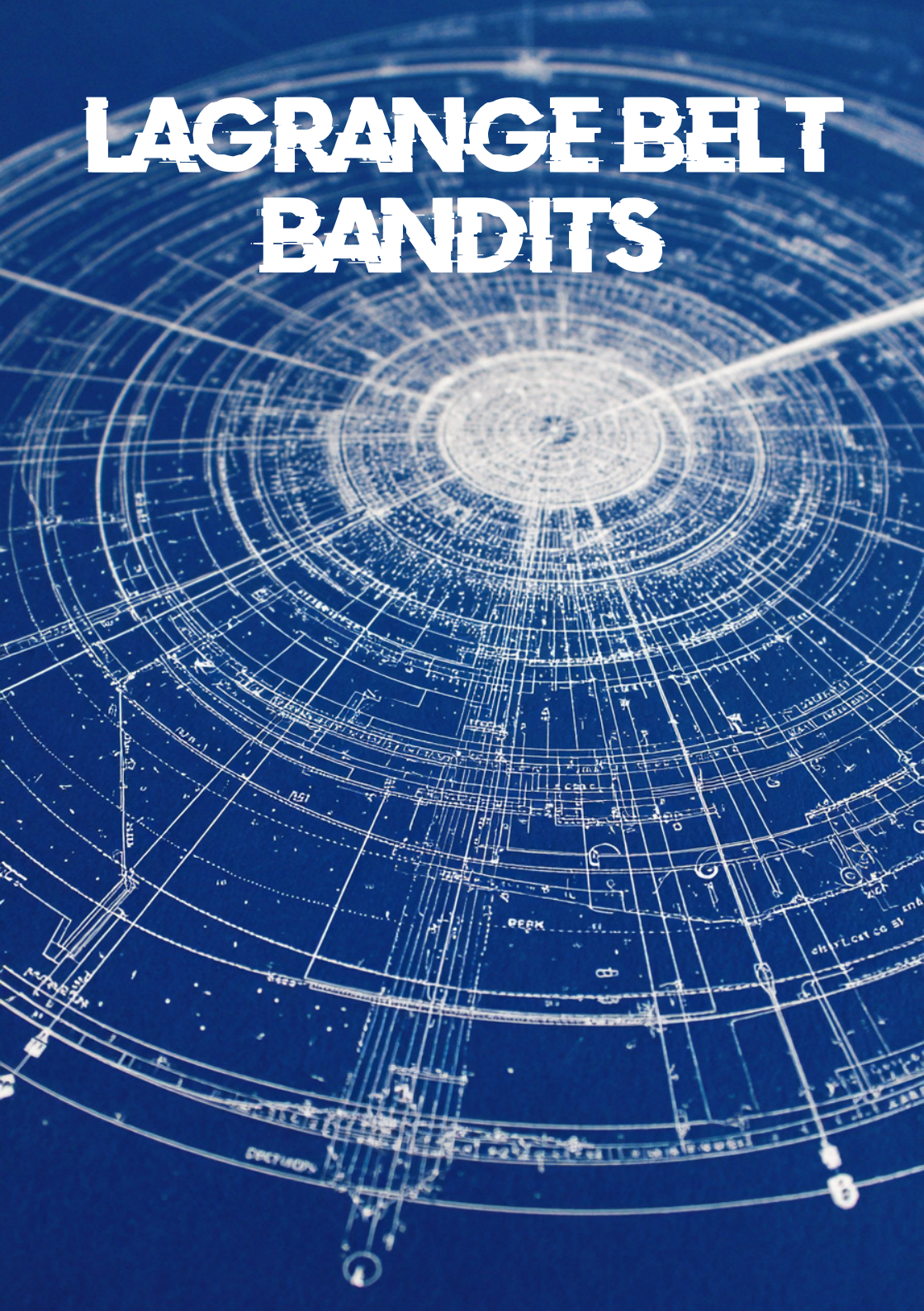



**Author:**

Me.

**Special Thanks:**

To nobody, since I did all the work myself. I don't have loved ones or family backing me, just nagging that I should "get paid for this" or I'm losing my time. Yeah, fuck off.

So, everything right about this is thanks to me. Everything wrong is on me too. It is what it is.

**Disclaimer:**

These rules are based on **Barbarians of Lemuria**. I do not own the copyright, nor do I have permission – and I'm not publishing the full ruleset. What follows are only quick references and conversions for my own setting. If you want the complete game or better examples, please support the creators and buy the book. They deserve it.

If you somehow paid for this, you were scammed. This is a fan-made, non-commercial work, created purely for enjoyment and shared with other fans.



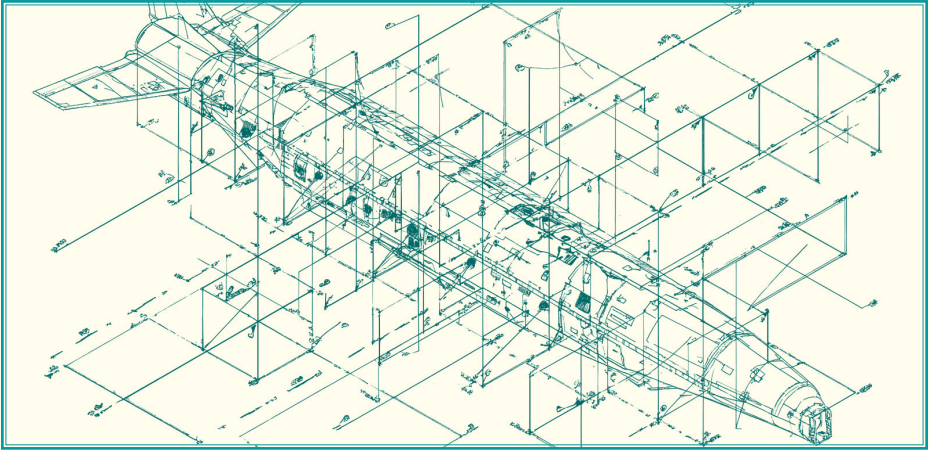

# THE CORE MECHANIC

The core mechanic is to Roll 2d6 + Attribute + one Skill (Combat or Career). Target number is usually 9, adjusted by the difficulty table.

- Natural 2: always a Failure.
- Natural 12: always a Success. If you would normally succeed, it becomes a Mighty Success.

Also, using Glitch Points you can:

- Upgrade a Success Mighty Success.
- Upgrade a Mighty (12) to a Legendary Success.
- Reroll once (including bonus dice).
- Gain 1 Glitch if you turn a natural 2 into a Calamitous Failure (worse situation).
- May also be spent for: Twist of Fate, Defy Death, Shatter Shield/Weapon, Luck of the Gods, Mighty/Legendary Success, Shake Off Wounds.

Glitch points are recovered at the end of an adventure.

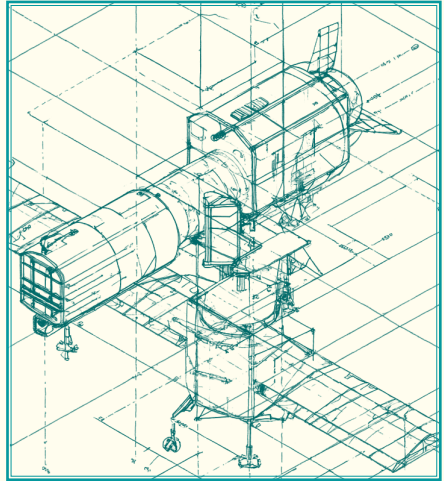

Difficulty	Modifier	Weapon Range
Very Easy	+2	-
Easy	+1	Point-Blank
Moderate	0	Close
Hard	-1	Medium
Tough	-2	Long
Demanding	-4	Distant
Formidable	-6	Extreme
Heroic	-8	Utmost



# COMBAT

## Who Acts First

Make a **Priority Roll**: Roll Mind + Initiative vs TN 9. Compare degrees of success (see table).

Ambush or Surprise: Attacked = Hard (-1) or worse; Characters ambushing = Very Easy (+2).

If a Villain/Tough has an Initiative score, subtract it from heroes' roll.

## Resolving Attacks

To resolve combat: Roll 2d6 + Attribute (Agility default) + Skill – Defense ± mods.

If you roll 9+ you succeed and can roll the damage dice. Subtract enemy Armor from damage.

## Combat Options

Options should be used cautiously, since they can slow things down.

- **Combat Stance**: Trade accuracy for defense or vice versa. For each step, gain +1 Attack / -1 Defense (or the reverse), up to +2 / -2.
- **Bypass Armor**: Take a penalty equal to the target's static armor rating to strike an unarmored spot (GM discretion).
- **Two-Weapon Fighting**: With light or medium one-handed weapons:
  - *One weapon for parrying (melee)*: +1 Defense, -1 Attack.
  - *Both weapons for offense*: Damage increases one step, but -1 to Attack. (Still only one attack roll.)

Priority	Character
1	PC with a <b>Legendary Success</b>
2	PC with a <b>Mighty Success</b>
3	PC with a <b>Success</b>
4	Villains
5	Toughs *
6	PC with a <b>Failure</b>
7	Rabble *
8	PC with a <b>Calamitous Failure</b>

\*: Cannot act 1st round if someone has a Mighty / Legendary roll.

## Margins Off Success

When you succeed with a Mighty Success you may choose one of the following (two on Legendary):

- +6 damage or Make one extra attack (no further Glitch Points allowed).
- Disarm weapon, but no damage.
- Foe up to 1 size larger is pushed or knocked down. If attacked again, they take a penalty die on next action.
- Hit a specific spot to maim or impose penalty dice.
- Against rabble, damage roll = number of foes taken out.

AVERAGE DAMAGE TABLE

Weapon	Dmg	Strenght Bonus
Brawling	d3	Half <i>strength</i> (round down)
Improvised	d3	Add <i>strength</i> (melee) or Half <i>strength</i> (thrown ranged)
Light	d6L	
Medium	d6	
Heavy	d6H	

Note:

d6L: roll an extra dice, keep lower.

d6H: roll an extra dice, keep higher.



## Careers in Combat

Careers don't apply in combat, but if your character can give a good reason, players may receive a small bonus. For example, an assassin striking from the shadows at an unaware opponent. These tactics only work once.

## Movement and Distance

Characters can move up to 25' per round, modified by *Agility* ×5. Running doubles that speed. Difficult terrains may require *Agility* tests

A character can move and take an action, or instead, only run.

A character can spend a Glitch point to alter the terrain to their advantage if it makes sense—for example, deciding that a maintenance area is full of hanging cables they can climb.

## Wounds and Death

When your Lifeblood reaches 0, you are stunned. On your next turn, you may spend a Glitch point to recover half your lost Lifeblood (round up) and keep fighting. If not, you pass out until the battle ends.

When your Lifeblood drops below 0, you are unconscious and lose 1 Lifeblood each round until you are stabilized, healed, use a Glitch point, or die.

At -6 or lower, you are dead (unless you spend a Glitch point).

Brawling damage never kills and is fully recovered after a rest.

## Recovery

After a fight, a 10–15 minute rest restores half your lost Lifeblood (round up).

After that, you regain 1 Lifeblood per day with only light activity.

Healing careers (Medic, Scientist with drugs): restore 1 Lifeblood per rank immediately. They may also attempt a Moderate task roll each day to double the recovery rate.

## Stabilizing the Dying

While below 0 Lifeblood, you keep losing 1 per round until -6.

Another character can stabilize you with a Moderate Mind + Career roll, with difficulty increased by +1 per negative Lifeblood. Once stabilized, you recover normally.

Most NPCs die at 0 Lifeblood, unless the GM rules otherwise for story reasons.



# CREATING A BANDIT

## *Attributes*

At character creation, you **divide 4 points between these four Attributes** as you like. You may even lower one Attribute to -1 to gain an extra point. The maximum starting rating is 3.

- **Strength:** This represents raw physical power, toughness, muscle and physique.
- **Agility:** This covers general speed, dexterity, reactions, coordination, and physical prowess.
- **Mind:** Intellect, willpower, knowledge, and perception.
- **Appeal:** This represents charm, persuasiveness, and overall presence.

## *Combat Abilities*

At creation, you **divide 4 points between these four Abilities**. You may lower one Ability to -1 to gain an extra point. The maximum starting rating is 3.

- **Initiative:** This represents awareness, alertness, and quick reactions in dangerous situations.
- **Melee:** This covers all close combat—fighting with weapons, fists, or grappling. Swords, knives, kicks, or wrestling are all part of Melee.
- **Ranged:** This is the ability to hit targets at a distance with firearms, or thrown weapons like knives.
- **Defense:** Dodging, parrying, sidestepping, or otherwise avoiding attacks.

## *Lifeblood*

Lifeblood represents how much damage a character can endure before collapsing. A character's Lifeblood equals 10 + Strength.

Whenever you are hit in combat, you lose Lifeblood according to the power of the attack. This loss is recorded as a number of points, subtracted from your current total.

## *Glitch Points*

Glitch Points represent errors in the system—anomalies, lucky breaks, or sudden shifts in probability that shouldn't happen, but do. They are the hiccups in reality that let someone survive an explosion, stumble into the right airlock, or hit the impossible shot.

Characters start with 5 Glitch Points. They can be spent during play to exploit these small fractures in the story—rerolling failures, twisting outcomes, or turning certain defeat into a narrow escape.

## *Traits: Boons and Flaws*

Boons are advantageous Traits, a mix of custom cyberware and unique competences that set your character apart, while Flaws are disadvantages that create complications for your character.

Every character begins with 1 free Boon. Additional Boons may be taken by either accepting a Flaw or permanently reducing your starting Glitch Points by 1.

At character creation, you may take up to 3 Boons.



## Advancement Points

At the end of a mission, the GM awards Advancement Points (AP). These can be spent to improve your character—raising Attributes, upgrading Combat Abilities, expanding Careers, gaining Boons, or attracting Followers.

**Improve Attributes:** Attributes can rise above their starting values. The AP cost is equal to the current value + new value. Example: Strength 1 > 2 costs 3 AP (1+2). Strength 2 > 3 costs 5 AP (2+3). Raising -1 > 0 costs 2 AP. Attributes may only increase one step at a time, and cannot exceed 5 unless a Boon allows it.

**Train Combat Abilities:** Combat Abilities can also be increased. The AP cost is new value + 1. Example: Melee 1 > 2 costs 3 AP (2+1). Melee 2 > 3 costs 4 AP (3+1). Raising -1 > 0 costs 1 AP. Combat Abilities cannot exceed 5.

**Develop Careers:** Career Ranks improve at a cost equal to the new rank. Example: Pilot 1 > 2 costs 2 AP. Rank 2 > 3 costs 3 AP. A new Career starts at Rank 0 for 1 AP. Careers cannot exceed Rank 5.

**Boons and Flaws:** You may spend 2 AP to gain a new Boon or remove a Flaw. Some Boons are only available at character creation, and some Flaws cannot be removed.

**Followers:** Reputation, notoriety, or influence may attract allies. For 1 AP, you may gain ten Rabble followers (1 Lifeblood each) or one Tough follower (built as a standard NPC Tough). These might be crew, mercenaries, or drones—depending on the setting.

## Careers

Careers represent a character's upbringing, training, and experience. They define what your character knows, what they can do, and the kind of influence they carry. A Career can cover anything from piloting, engineering, or hacking, to mercenary work, medicine, or underworld contacts.

At character creation, **choose 4 Careers and divide 4 points between them.** Each Career must be at least Rank 0, and no starting Career may be higher than Rank 3.

Your Careers give you an immediate sense of who your character is, a high Rank suggests long experience in that path, while a Rank of 0 may mean only brief exposure—or just a natural knack for it.



# CAREERS

## *Analyst (Researcher, Scholar)*

Analysts are researchers and knowledge-keepers, trained to process and interpret vast amounts of information. They may be historians, linguists, philosophers, or data scientists, but they share a drive to uncover, preserve, and explain knowledge. Many work as advisors, archivists, or consultants, guiding others with their expertise.

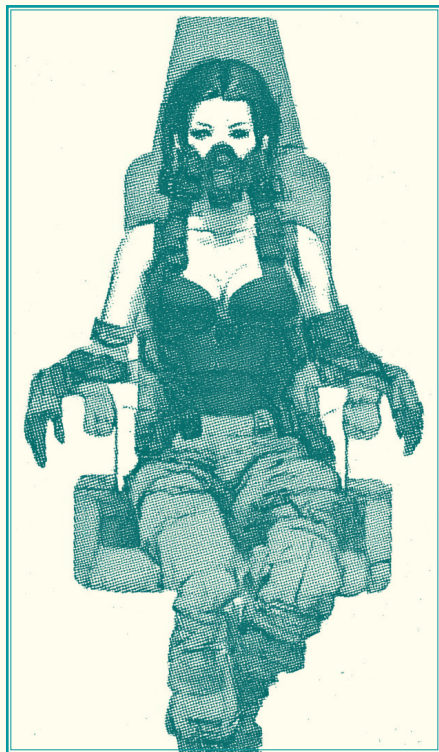

## *Assassin (Agent, Spy)*

Assassins and covert operatives live by precision, patience, and discretion. They specialize in infiltration, surveillance, disguise, and eliminating targets without drawing attention. Their skills may include stealth movement, gathering intelligence from shady sources, bypassing electronic security systems, or crafting and using poisons.

Assassins are known for building networks of contacts, blending into new environments with practiced ease, and waiting for the perfect opportunity to strike. Many work as freelance killers or spies, though some serve governments, corporations, or criminal syndicates.



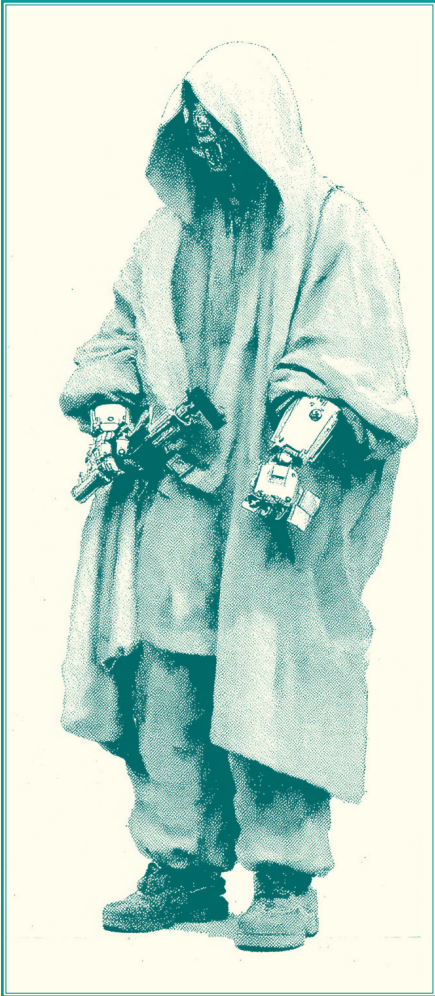

### *Beggar (Hobo, Vagabond)*

Beggars are wanderers and outcasts, drifting through the streets and surviving however they can. Some take odd jobs or sell trinkets, others resort to begging or petty crime. They often know how to stay unnoticed, slip through crowded districts, and survive on scraps when resources are scarce.

### *Bounty Hunter (Scout, Tracker)*

Bounty Hunters specialize in tracking and capturing people. Whether they're chasing fugitives, debt-dodgers, or targets of questionable contracts, their skillset is the same: follow the trail, stay unnoticed, and bring the quarry in—dead or alive. They rely on stealth, traps, surveillance, and precision weapons to finish the job.





### *Corporate Drone (Clerk)*

Corporate Drones fill the lower tiers of the system—endless office workers managing accounts and trade records, or technicians running biohabs, algae vats, and protein nurseries. Their work is repetitive and thankless, but it provides practical knowledge of corporations, supply chains, and food or biotech production. They know how the machinery of daily life runs—whether through spreadsheets or hydroponics.



### *Dancer (Acrobat, Tumbler)*

Dancers remain central to entertainment—whether in nightclubs, neon-lit stages, festivals, or private venues. They blend athleticism and performance, displaying agility, coordination, and stamina. Some incorporate acrobatics, sleight-of-hand, or prop work into their shows, while others rely on rhythm and provocative displays to capture attention.



### *Elite (Politician, Diplomat)*

Elites move within the highest spheres of power—executives, politicians, or wealthy elites with influence that reaches far beyond the streets. They maintain networks of contacts, secure credit and resources, and excel at manipulation through charm, intimidation, or negotiation. Whether in boardrooms, senate chambers, or diplomatic halls, they know how to bend situations to their advantage.



### *Ganger (Berserker, Savage)*

Gangers grow up fighting for survival in the streets and alleys of the city sprawl. They live in a constant struggle for territory, reputation, and dominance. Their instincts are honed by turf wars and brutal rivalries, giving them a knack for street survival, intimidation, and knowing how to move through the urban jungle.

Some Gangers rely on raw ferocity, throwing themselves into berserk rages when pushed. Others lean on street smarts, ambush tactics, or their reputation to survive. However they fight, they are marked by violence and resilience.



## *Hacker (Netrunner, Cybermancer)*

Hackers are both respected and feared. They exploit cracks in networks, override security, and bend digital systems to their will. Some specialize in corporate espionage or data theft, while others push deeper, breaking into cybernetic implants, drones, or even entire AI cores. Their skills can unleash chaos in the physical world, but always at a cost—hacking is risky, unpredictable, and dangerous.

Most Hackers work alone, surrounded by equipment, code, and the occasional apprentice or digital construct. They dig through encrypted archives, breach black networks, and manipulate systems that were never meant to be touched.

**Perilous Career:** Hacking is a fast track to power, but it always carries a price. For each Rank above 1 in this Career, the character must take an additional Flaw.

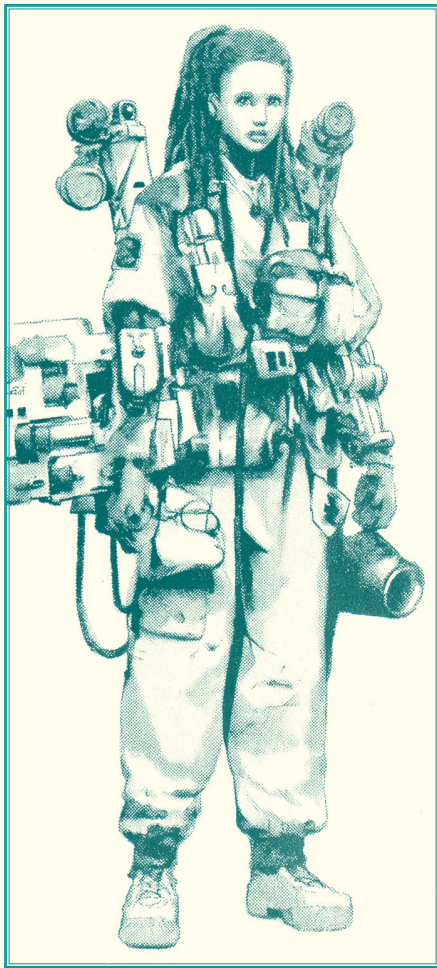

## *Medic (Doctor, Field Surgeon)*

Medics are trained professionals who keep people alive when things go wrong. They diagnose injuries and illnesses, perform surgery, and apply treatments ranging from high-tech pharmaceuticals to improvised field care. Some work in sterile hospitals and clinics, while others patch up soldiers, gang fighters, or crews in makeshift medbays.



## *Merchant (Contrabandist)*

Merchants are travelers, deal-makers, and brokers of rare goods. They specialize in trading, appraisal, persuasion, and securing unusual items through their networks. A Merchant may know where to find exotic tech, who controls a market, or which contacts can quietly move restricted goods.

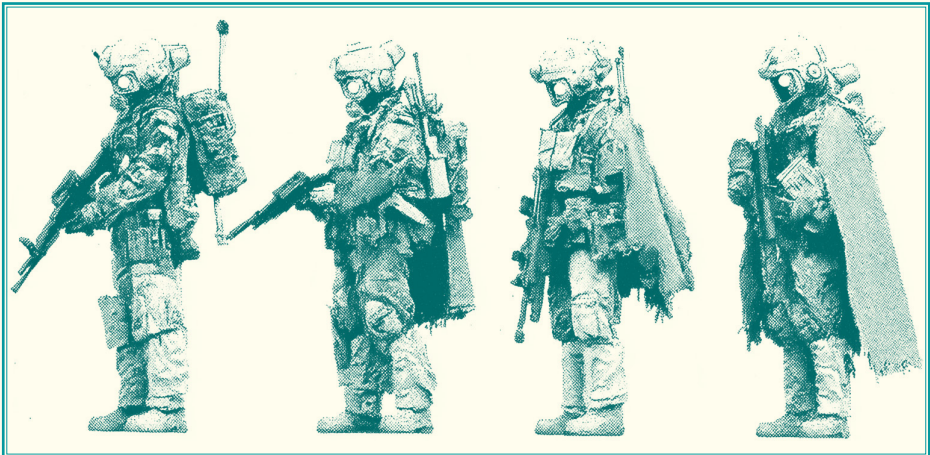

## *Mercenary (Bandit, Warrior)*

Mercenaries fight for anyone willing to pay. Some band together under strong leaders, while others work alone or in small crews. When work dries up, many drift into crime or banditry to survive. They are skilled in intimidation, carousing, and the upkeep of weapons and armor, and often know how to live rough between jobs.



## *Performer (Artist, Icon)*

Performers thrive on attention, weaving art, music, stories, or spectacle to captivate an audience. They may sing, play instruments, act, or broadcast to the masses, shaping how people see the world—or simply chasing fame and fortune. Some work the streets and clubs, while others are kept by patrons, corporations, or syndicates as prized entertainers.



## *Pit Fighter (Brawler, Enforcer)*

Pit Fighters specialize in brutal, one-on-one combat, often in underground arenas, gang-run fight clubs, or corporate black sites. They master a wide range of weapons and unarmed techniques, fighting for money, reputation, or survival. Some are forced into the pits by debt or coercion, while others seek fame in the underground circuit.



## *Rigger (AI Controller, Roboticist)*

Riggers have a natural knack for working with machines, AIs, and remote systems. They pilot drones for scouting or combat, maintain autonomous units, and know how to coax useful behavior out of stubborn programming. Some specialize in swarms of small drones, while others bond with a single heavy-duty platform, treating it almost like a companion.

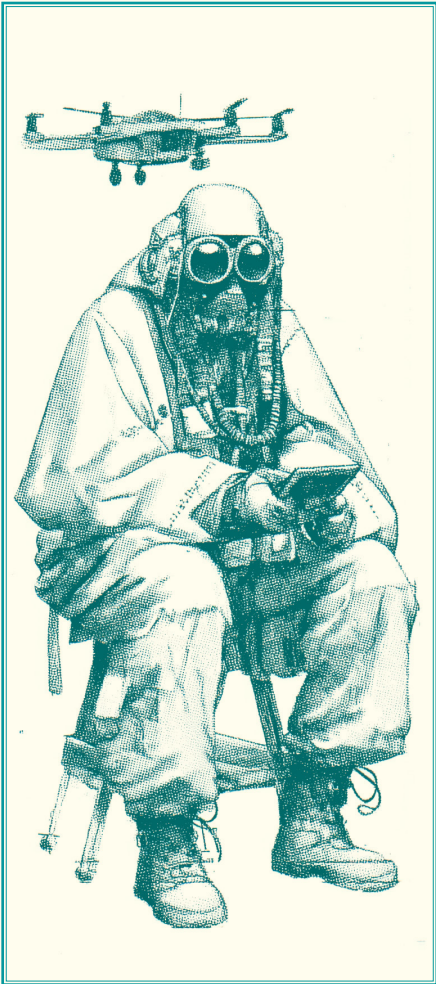

## *Scientist (Inventor, Fabricator)*

Scientists are the builders and innovators of the future. They combine chemistry, engineering, and fabrication to create devices, machines, and materials beyond ordinary reach. Their work may involve alloys, experimental fuels, biotech grafts, synthetic drugs, or strange prototypes that push the limits of what's possible.

Some scientists specialize in lab work—designing compounds, drugs, or toxins. Others are tinkerers and inventors, creating custom drones, weapons, or gear.

**Perilous Career:** For each Rank above 2 in this Career, the character must take a Flaw.



## *Slave (Serf, Thrall)*

Slavery is not a career of choice, but it can still shape a character's background. It offers skills others may not develop—knowing how to stay unnoticed, listen carefully, move quietly, or take on menial work such as cooking, cleaning, sewing, or hard labor. Some slaves, especially the strong or the rebellious, are forced into fighting pits or dangerous tasks.

## *Slaver (Executioner, Torturer)*

Slavers profit from the trade of lives—capturing, transporting, and selling people as property. They may raid frontier zones, buy captives from gangs or warlords, or run auctions in hidden markets. Their skills revolve around intimidation, restraint, and breaking spirits, though some are also shrewd negotiators who know the value of fear.

Executioners and Torturers fill the darker side of this spectrum. Executioners enforce public justice with brutal displays of violence, while Torturers specialize in interrogation, extracting information through fear and pain.

## *Soldier (Guard, Militiaman)*

Soldiers are the backbone of corporate security forces, planetary militias, or standing armies. They are disciplined, trained for conflict, and used to following orders, though not always known for creativity. Their background may also grant them some authority, knowledge of city or station life, and basic intimidation skills. Officers, in particular, learn how to command troops and manage the chaos of battle.





## *Spacer (Corsair, Pirate)*

Spacers are ship crews, captains, and raiders who live among the stars. They are skilled in navigation, piloting, ship maintenance, and the knowledge of ports, stations, and trade routes. Pirates and corsairs thrive on the same skills, turning them toward smuggling, raiding, or outright warfare.

Experienced Spacers are always in demand and rarely lack for passage on a vessel. They know the slang, codes, and customs of life between the stars, and many live by their reputation as much as their skill.

## *Starfighter Pilot (Ace, Hotshot)*

Starfighter Pilots are the elite among spacefaring combatants, trained to fly high-performance strike craft in the vacuum of space. They are daring, reckless at times, and admired by those bound to larger ships or planetside duties. Along with expert piloting, they are skilled navigators, sharp-eyed scouts, and often serve as couriers or escorts. Many are former military, and some carry the swagger of nobility or privilege.

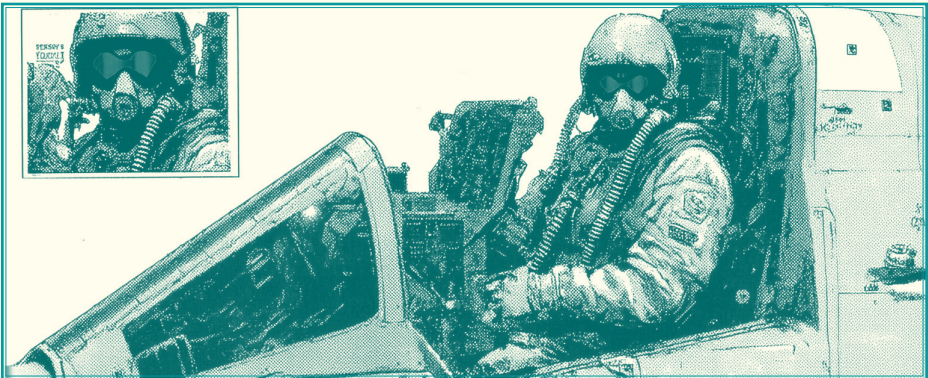

## *Technician (Armourer)*

Technicians are the builders and fixers of the tech world. They construct, maintain, and repair equipment, vehicles, and weapons, often working alongside Scientists or other specialists to bring new designs to life. They are skilled in fabrication, electronics, and mechanical systems, and can patch up gear in the field or assemble custom rigs in a workshop.

Technicians are also valued for their knowledge of tools, materials, and schematics, which gives them an edge when trading, bargaining, or sourcing rare parts.



## *Temptress (Escort, Socialite)*

Some people hone charm, seduction, and manipulation into powerful tools. A Temptress may be a corporate escort, a socialite, or someone who blends into clubs and dives, using beauty, wit, and presence to bend others to their will. Dangerous as they are alluring, they can stir rivalries, extract secrets, or make others fight their battles for them.

They are skilled in fashion, conversation, seduction, and reading social cues, as well as subtle theft or misdirection. In the right setting, their influence can be as effective as a weapon.



## *Thief (Rogue. Scoundrel)*

Thieves live by taking what isn't theirs—sometimes out of necessity, sometimes out of greed. Whether growing up as street urchins or turning to crime later in life, they develop skills others find unsavory. Burglary, climbing, sneaking, pocket-picking, gambling, and knowing the right (or wrong) people are all part of the trade.



## *Worker (Docker)*

Workers perform the heavy labor—loading cargo in orbital docks, maintaining warehouses, or operating industrial exosuits and heavy machinery. Their days are long, their tasks repetitive, but their strength and resilience make them essential in any supply chain.



# BOONS & FLAWS

At character creation, each player starts with one free Boon. Additional Boons can be gained by taking on Flaws (as explained earlier) or by spending Advancement Points.

**Boons & Flaws** are a mix of special abilities and cybernetic grafts—most often the latter. These aren't just numbers on a sheet; you decide how they look and feel on your character. Maybe your strength comes from synthetic muscle bundles stitched onto your bones, or maybe it's an exoskeleton frame bolted directly into your skeleton. Your body, your story.

Take into account that most cyberware is hard to miss unless you choose the Boon Masked. Technology hasn't advanced far enough to blend seamlessly into flesh. The average implant is bulky and raw—oversized cranial plates, bulbous camera-eyes, antennas jutting from the skull. That's the norm.

**Boons** come with descriptions, but those are just examples. As mentioned, you're free to customize your aspect.

Note: Bonus dice from Boons doesn't Stack.

## Boons

### Atlas Spine

Your natural spine has been replaced with a reinforced cybernetic column, bolted into widened shoulder plates and pelvic anchors. Limb joints are rebuilt with hardened couplings that lock and hold under strain. When lifting or forcing something, you can see the spine plates ratchet and hiss, bracing your frame to bear impossible weight.

**Effect:** Roll a bonus die when breaking, lifting, pulling, or pushing things.

### Augmented Fab-Lab

Your body bristles with integrated tool arms, soldering tips, and chemical injectors, all sprouting from a broad, bolted backpack-frame that houses a portable fabrication unit. Cables and tubing run directly into your torso, drawing on your own circulation for cooling and waste handling. You carry your workshop everywhere you go, but raw feedstock and reagents still need to be hunted down and replenished.

**Effect:** Roll a bonus die when making alchemical preparations or mechanical devices while using your fab-lab. It must be restocked from time to time, which may require risky excursions to secure materials.

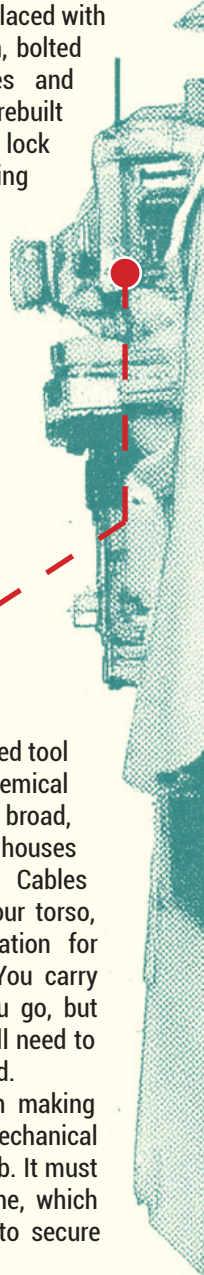

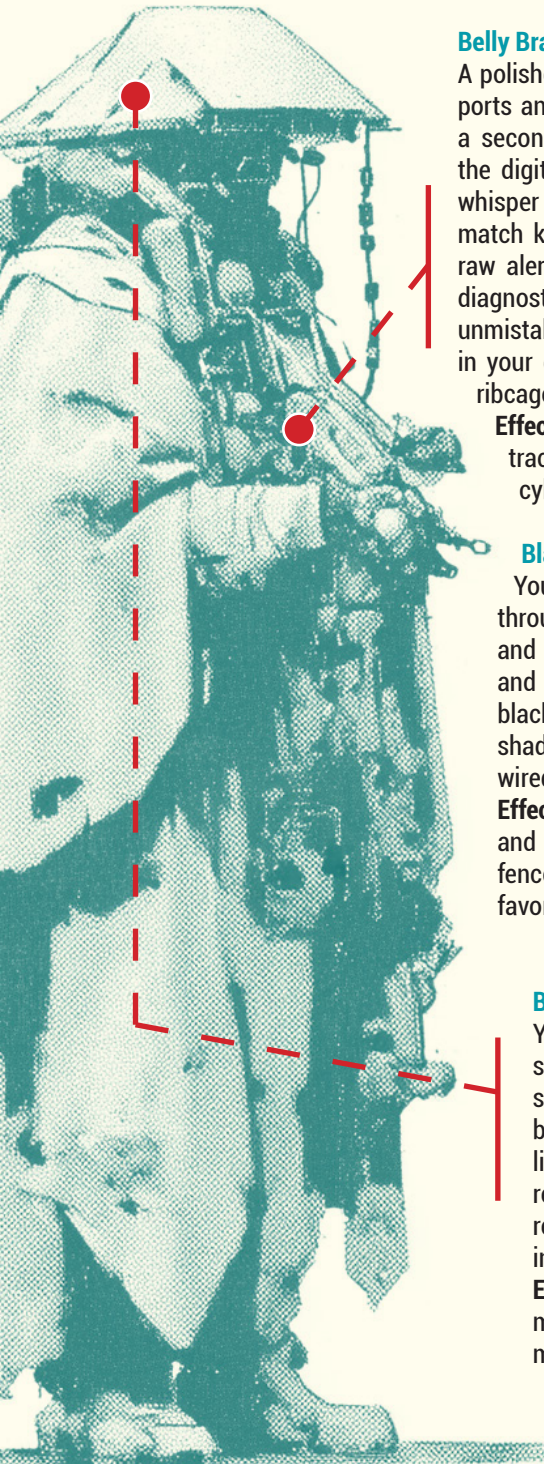

### Belly Brain

A polished metallic orb is grafted into your abdomen, ports and conduits sunk into the flesh around it. It's a second brain—an auxiliary AI core that listens to the digital hum of the world. When nearby systems whisper of intrusion, comms flicker, or code-patterns match known hacks, the belly brain pulses, sending raw alerts into your nervous system and overlaying diagnostic hints into your vision. The module looks unmistakable: a shining, ventilated globe half-buried in your gut, with braided cables vanishing into your ribcage.

**Effect:** Roll a bonus die when attempting to spot or track hackers, rogue AIs, or digital intrusions (the cyber-equivalent of sensing magic).

### Blackwire Uplink

Your underworld contacts are patched into you through hidden comm-links, pirated channels, and data scramblers grafted into your jawline and spine. Your visor feeds with smuggler codes, black market listings, and gang chatter from the shadows. You don't just know the streets—you are wired into them.

**Effect:** You have friends in various hives of scum and villainy. They can offer you hiding places, fences, illicit contacts, and other underworld favors.

### Braincase

Your cranial housing has been rebuilt into a rigid shell—sometimes styled like an ornamental hat, sometimes as an enlarged metallic skull. Wide brims, tall crowns, or ribbed casings vent faint light and heat when the system engages. Inside rests an advanced neural array that sharpens recall, restructures memory, and feeds patterns into your thoughts.

**Effect:** Add +1 to your Mind attribute. Your maximum Mind is 6 rather than 5, and your maximum starting Mind is 4 rather than 3.

### Bulk Frame

Synthetic muscle bundles, hydraulic actuators, and a grafted exoskeleton laced into your bones swell your frame beyond human limits. Each step lands heavy, every grip can bend steel. The modifications are obvious—thickened limbs, reinforced joints, and the unmistakable bulk of someone rebuilt for raw power.

**Effect:** You may add +1 to your Strength. Your maximum Strength is 6 rather than 5, and your maximum starting Strength is 4 rather than 3.

### Carapace Plating

Sections of synthetic armor replace the skin itself, bolted and anchored directly into the bones and major joints. The result is a hard, visible shell that provides full coverage and an unmistakably augmented look.

**Effect:** Counts as medium armor with no penalties.

### Chem-Nose Array

A cluster of protruding vents and sensor nodes mounted along your jawline and temples constantly sample the air. They break down chemical signatures into streams of data—tracing a pursuer's sweat, sniffing out leaking gas lines, or flagging toxic oxygen mixes before they drop you cold. In a fight, you can even track enemies by the scent of their stress.

**Effect:** Roll a bonus die when attempting to perceive something using smell.



### Cranial Data Loom

Your skull bulges with grafted memory modules, dangling coolant lines, and embedded storage coils hidden beneath a massive, heat-dissipating headpiece. Wide-brimmed hats and dangling cables are not decoration but vital cooling systems. You carry your library with you, though data must still be replenished and refreshed.

**Effect:** Roll a bonus die on any rolls to find out information while using your cranial library. The library needs to be restocked from time to time, sometimes requiring dangerous excursions to acquire new data.

### Cue Canisters

A line of visible memory canisters runs along the outside of your arm, each filled with compressed dialogue cues and rehearsed lies. A thin antenna feeds them constant updates from the net. When a bluff fails, one canister burns out with a fizz of smoke and light, like a blown fuse, leaving a blackened slot until you replace it.

**Effect:** Roll a bonus die whenever trying to lie, con, fast-talk, or otherwise deceive someone.

### Cyberlimb & Spinal Reinforcement

Enhanced cyberlimbs fitted with synthetic muscle bundles, shock-absorbing joints, and a reinforced spinal column to anchor it all. Movements are powerful and fluid, letting you sprint, climb, swim, or leap with ease even in low-G.

**Effect:** Roll a bonus die when performing athletic activities (not fighting).

### Dogbrain

A compact metallic AI core sits in your shoulder or along the collarbone ridge. It monitors hostile network pulses and launches silent counter-routines when someone hacks at you. When the core successfully blocks an attack, its fans and vents roar as it hyperventilates to cool down, sending sharp clicks and hisses into the air.

**Effect:** If a hacker or rogue AI targets you with a digital attack, roll a d6. On a roll of 6, the attack fails.



## Drone Control Nexus

A cranial implant and neural interface tuned for piloting semi-autonomous drones, AI companions, and robotic assistants. Lets you coordinate, direct, or empathize with machines as if they were extensions of your own body. Often paired with swarms of microdrones or a loyal robotic companion.

**Effect:** Roll a bonus die when dealing with drones, AIs, or robots. If you are a Rigger, you also have two or three small drone companions, or one medium/large robotic companion.

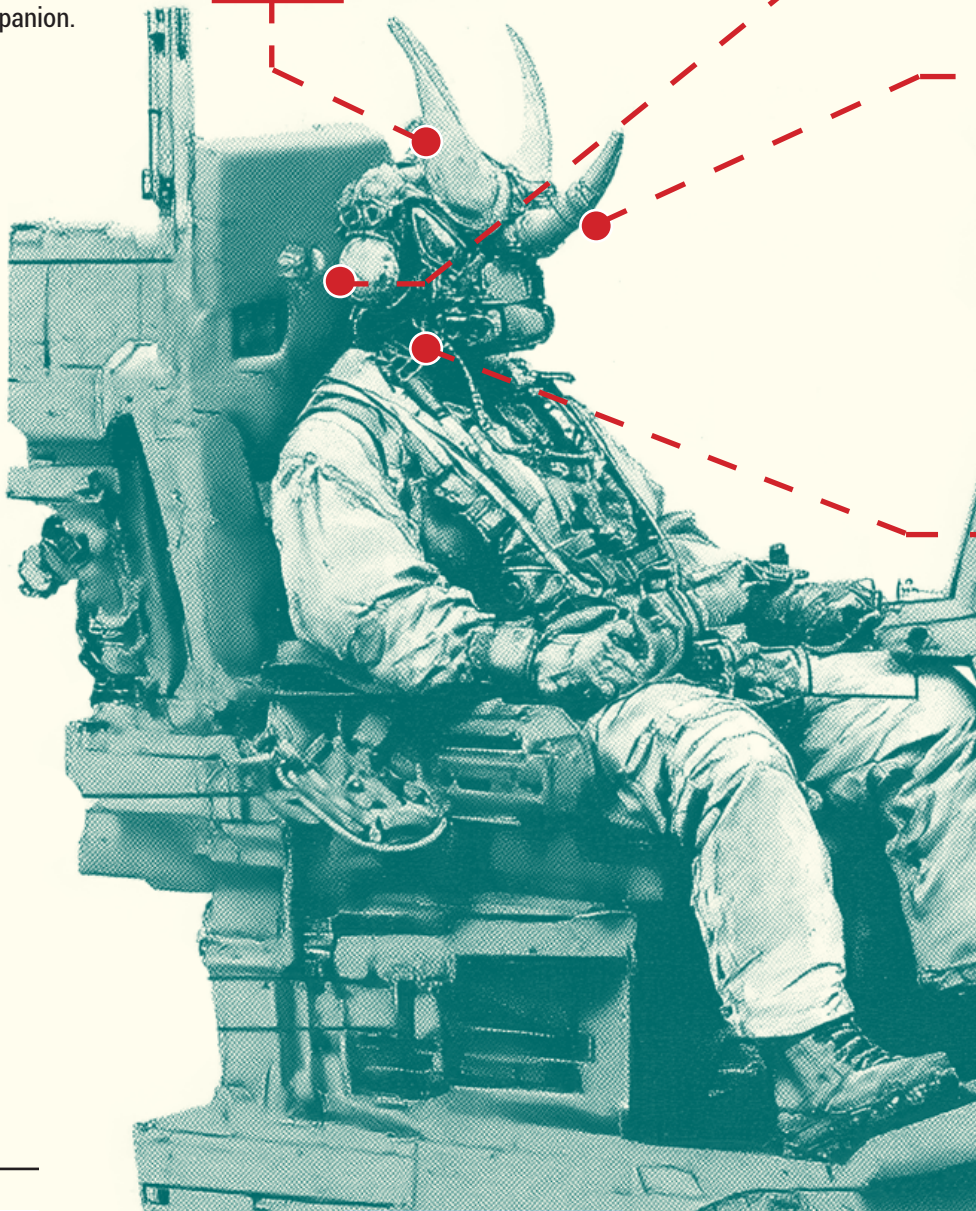

### Echaware

Curved metal bands are bolted into the skull at the ears and fuse across the back of the head like a rigid inverted visor. The structure is clearly grafted—cables, rivets, and sockets visible where metal meets bone. Bristling with contact mics and resonance pickups, it turns your skull into a listening array. Every creak of a bulkhead, the shuffle of boots on a distant deck, or the stutter of a hidden transmitter registers with clarity.

**Effect:** Roll a bonus die when attempting to perceive something using hearing.

### Elite Channel Uplink

Your contacts in the corporate and political elite are reinforced by hardware: visor displays that never stop streaming private channels, encrypted feeds from orbiting drones, and backdoor access to data lines meant for the powerful. You don't just know the right people—you are wired directly into their world.

**Effect:** You have contacts within the upper echelons of society. They will offer aid, expecting a favor in return when it suits their interests (introductions, information, political leverage, etc.).

### Etiquette Chipware

Your implants carry deep databases of etiquette, diplomatic codes, and corporate protocols. Internal assistant processes whisper corrections directly into your thoughts, while personality modules can nudge posture, tone, and micro-expressions until you act like someone born to the court. In practice you don't just remember manners—you become them on cue.

**Effect:** Roll a bonus die when dealing with courtly manners, diplomatic encounters, or corporate protocol.

### Extruder Arm

A compact auxiliary arm is bolted into your shoulder or upper torso, smaller than your main limbs but loaded with nozzles, feed slots, and rotating tool-heads. Material cartridges slot into its housing, glowing faintly as polymers, alloys, or compounds are extruded into precise components. When engaged, the arm hisses and hums, layering structures with mechanical precision right beside you.

**Effect:** You gain Craft Points as a Technician, but only for making common and uncommon weapons, armors, and tools. You may also assist (that is, add your Craft Points) to devices and creations (not drugs) made by a Scientist. You must have the Technician career to take this boon.

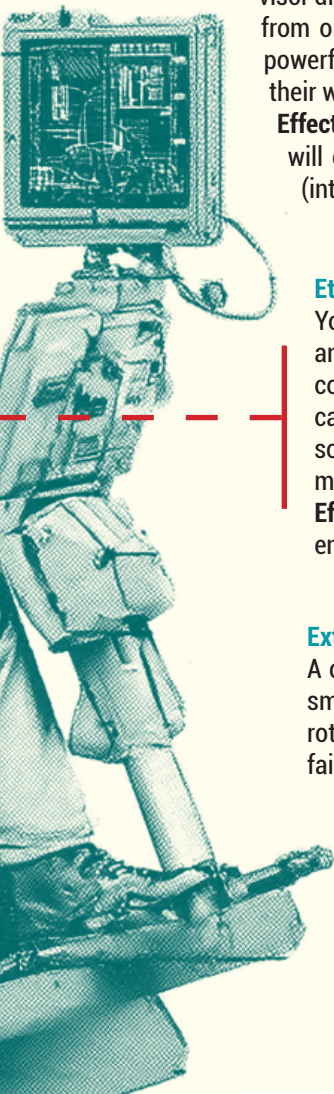

### Filter Organs

Your liver and kidneys are replaced with synthetic filters housed in visible armored ridges under the ribs and back. Tubes and valves vent waste with faint hisses, showing the constant cleansing at work.

**Effect:** Roll a bonus die whenever you are resisting the effects of drugs, venoms, toxins, or alcohol.

### Flexi-Joints

Cybernetically enhanced ligaments and double-jointed bones let you bend, twist, and contort in ways that would snap a normal body. Combined with micro-cutters hidden under the fingernails, no rope, chain, or manacle can hold you for long.

**Effect:** Roll a bonus die whenever you are trying to break free from restraints or confinement.

### Glitched

Something in your cybernetics isn't standard—it glitches in ways no one can fully chart. Lights flicker when you enter a room, comms hiss with static at your approach, and sometimes the world skips like a broken feed. Techs mutter about corrupted firmware or phantom code, but no fix ever holds. Whatever it is, the flaw tilts chance to your side.

**Effect:** You gain an extra Glitch Point.

### Gyro-Thrusters

Retractable micro-thrusters grafted into the torso and gyroscopic stabilizers fused to the spine grant perfect control in freefall. With each twitch of intent, your body rights itself and coasts exactly where you want it to go.

**Effect:** Roll a bonus die when performing non-combat physical activities in zero-G environments.

### Hackdeck Core

A bulky cluster of memory modules and heat vents is grafted into your chest and upper spine, the plates rising and falling as the system churns. A handful of cable-jacks still run to cranial ports, but most of the processing power lives in the torso, with pulsing lights and faint hums betraying when the deck is active.

**Effect:** Roll a bonus die when attempting to perform hacks. You must also take an extra flaw.

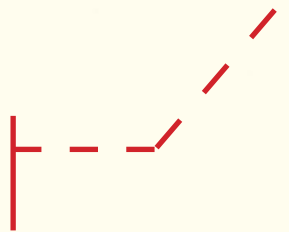
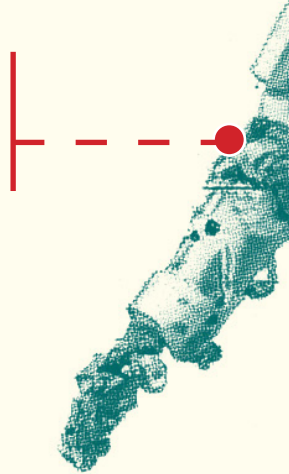

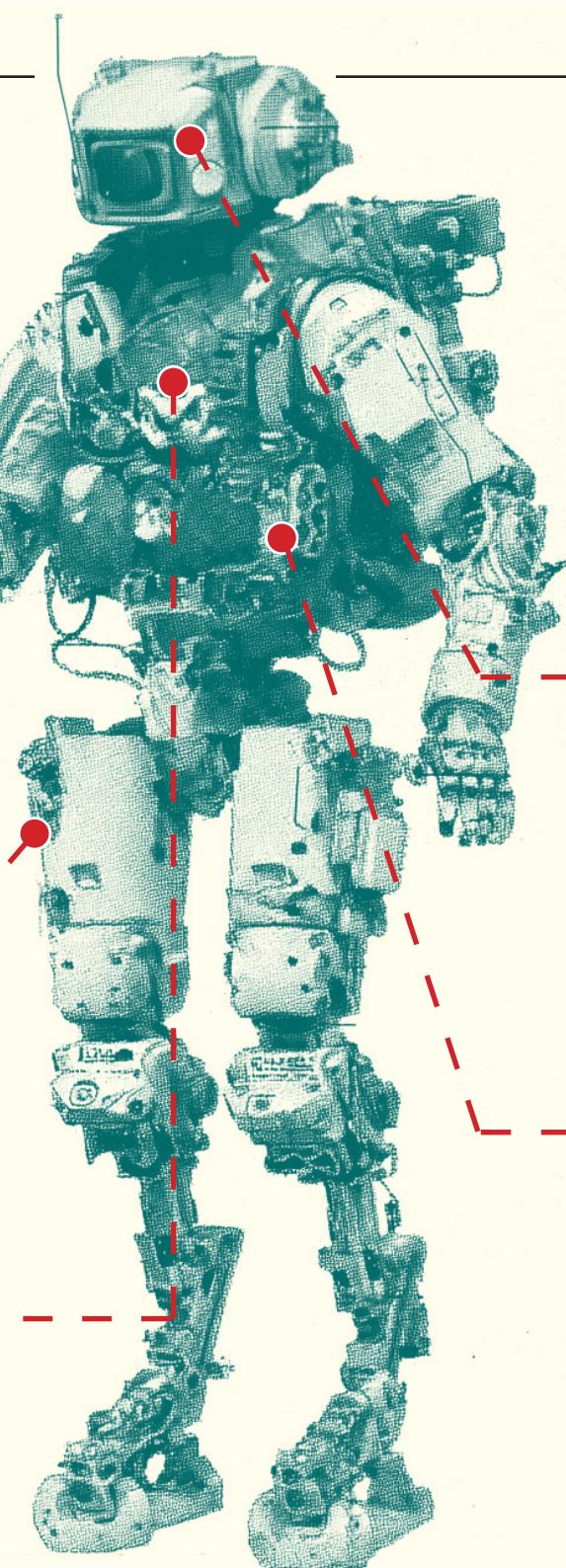

### Hammer Hands

Hydraulic rams and piston-driven knuckles jut from your forearms, built like the tools used to strip concrete and break rock. Each strike lands with the force of a piledriver, accompanied by the hiss of hydraulics and the crack of impact plating.

**Effect:** Add your full Strength to damage caused when fighting unarmed.

### Hawkeye Lenses

Bulbous optical implants bristling with zoom lenses, spectral filters, and motion trackers jut from your face, replacing natural eyes with raw machinery. You see details others miss—heat leaks, micro-movements, distant glints.

**Effect:** Roll a bonus die when attempting to perceive something using eyesight.

### Hormone Clamp

A deep-brain implant regulates adrenaline and cortisol output, shutting down fear responses before they can spiral. Drug-inducible anxiety, panic, or terror simply never reach the conscious mind. Outwardly, your expression barely changes even in life-or-death moments.

**Effect:** You show no fear. Even drug-induced fear has no effect on you.

### Immune-System Overclock

A full-body implant that constantly monitors blood chemistry and floods your system with nanomedical countermeasures at the first sign of infection. Visible injection ports and dermal nodes betray the constant work going on beneath the skin.

**Effect:** You are immune to all diseases, even engineered or exotic ones.

### Influence Suite

A blend of subdermal pheromone glands, voice modulators, and subliminal signal emitters engineered to bypass rational thought. Combined with sculpted aesthetics and coded micro-expressions, you become dangerously persuasive to anyone susceptible.

**Effect:** Once per day you may suggest a course of action to a number of rabble equal to appeal + d6, who will do their best to please you, even if it puts them in danger. Requires the Temptress career.

### Integrated Arsenal

Your body itself conceals your iconic weapon. For some it's a hidden blade that slides from the forearm; for others a shoulder-mounted firearm that deploys with a snap. Because it is built into you, practice and instinct merge—the weapon feels like a natural extension of your frame. The implant is always visible in some form: arm plating with seams, a recessed muzzle port, or jointed sheath-lines hinting at what lies inside.

**Effect:** When using your integrated weapon (or a custom replacement built to the same design if lost), you receive a bonus die.

### Ironhide Frame

Layers of subdermal Kevlar mesh, ceramic inserts, and a reinforced endoskeleton make your body stubbornly hard to put down. Impact scars the surface but rarely reaches your vitals, and broken bones often hold together long enough to keep fighting.

**Effect:** Add +2 lifeblood to your total.

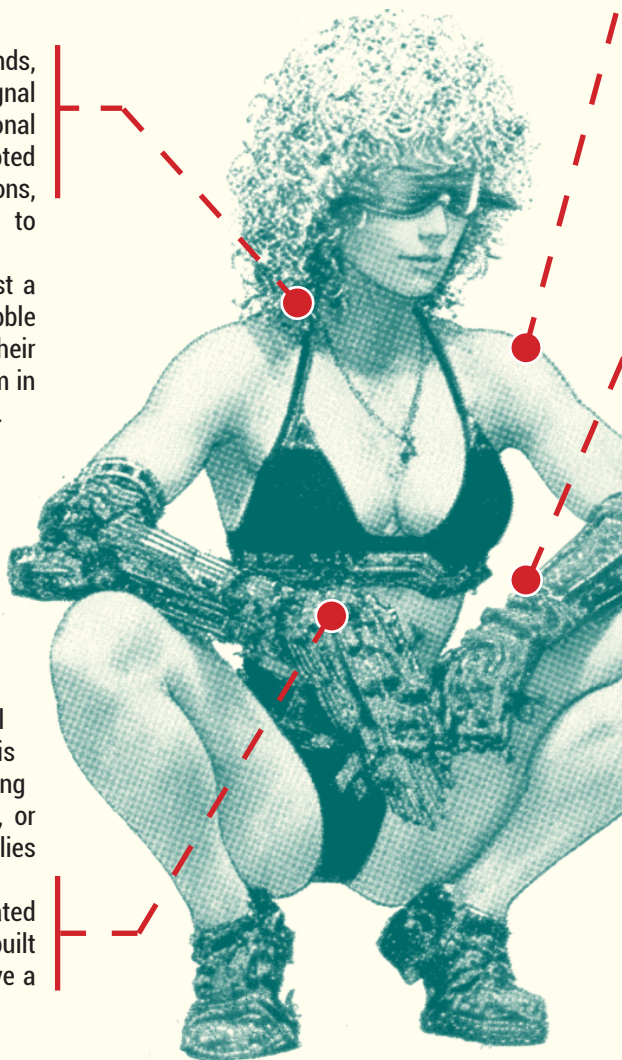

### Kevlar Weave

Beneath the outer shell of your body runs a visible lattice of synthetic fibers and armored mesh, anchored along ribs and limbs. It doesn't stop every hit, but when blades or rounds punch through, the weave catches the edge and keeps it from tearing into your vitals. Raised seams and interlaced ridges show where the reinforcement sits under the skin.

**Effect:** Gain +1 to your protection from damage, even when not wearing armor.

### Launcher Arm

Your cybernetic arm is fitted with either an integrated launcher or myomer-snapping muscles designed for brutal throwing force. Some models hurl knives, spikes, or shuriken with pneumatic acceleration; others just amplify your throws until they hit like a cannon.

**Effect:** With your selected type of thrown weapon, you may add your full Strength to the damage on a hit.

### Market Uplink

A crown of jutting antennae, and flickering sensor rods sprouts from the back of your neck, always twitching and scanning for new frequencies. These grafts hunt for corporate tickers, black market whispers, and settlement chatter across the void, feeding it straight into your visor. With one glance you know where to buy cheap, where to sell dear, and how to move goods before others even notice.

**Effect:** Roll a bonus die on any attempt to obtain goods, services, or other items you need while in a settlement or hub.

### Martial Frame

Upgraded cyberlimbs paired with a reinforced spine and martial-arts chipware give you superior control over strikes, holds, and throws. Your movements look rehearsed and precise, almost choreographed, turning your body into a disciplined weapon rather than a blunt one.

**Effect:** Roll a bonus die to attack when fighting unarmed with martial arts techniques.

### Masked

Top-tier cybernetics cloak your augments beneath a seamless veneer. Layers of synthetic skin replicate pores, warmth, breath, even a faint pulse. With a thought, parameters shift—bone structure, eye color, voice timbre—letting you pass as someone else entirely. Unlike most crude implants, yours vanish into the illusion of normal flesh. Masked also allows you to hide the existence of your other cyberware, making you appear as if you were a baseline human.

**Effect:** You gain a bonus die whenever trying to conceal your true identity. You may also spend a Glitch Point to suddenly appear in a scene disguised as a background extra, revealing you were present all along.



### Med-Palm Graft

Your face carries a scatter of extra optics, each darting and focusing as they scan for wounds, toxins, or failing vitals. Meanwhile, your hands hide micro-injectors and coagulant sprayers, turning a simple touch into a full diagnostic and treatment interface. The effect is equal parts medicine and menace—hands that pierce as easily as they heal.

**Effect:** Roll a bonus die whenever helping someone recover from injury, poison, or similar harm. Requires the Medic career.

### Med Vats

Reinforced crystal canisters protrude from your shoulders, glowing with swirling nanomachines and chems. When triggered, they hiss and inject through visible tubing, flooding your bloodstream. The sight is unsettling—fluid coursing into you as tissue stitches and bruises fade in moments.

**Effect:** When recovering after combat, regain one additional lifeblood on top of the normal half. You also recover one lifeblood each day regardless of activity.

### Mnemonic Core

At the back of your skull sits a honeycomb cluster of cylindrical condensers and glowing data cells, venting heat in bursts of steam or light whenever the system runs hot. This lattice hums faintly as it pulls up archives of texts, recordings, and stored knowledge, then feeds them straight into your vision.

**Effect:** Roll a bonus die when recalling a fact from your area of specialty.

### Neural Creative Suite

Clusters of shimmering cortical implants bridge the prefrontal cortex and visual centers, laced with micro-LED veins that flicker faintly when inspiration hits. Linked databanks and low-grade AIs flood your mind with archived art, design heuristics, and historical aesthetics, offering patterns, palettes, and shapes before you consciously imagine them.

**Effect:** Roll a bonus die when appraising or creating items of art.





### Noctis Optics

In normal light, your eyes look natural—until the system engages. The outer layer of your eyes and the ridge of your nose split open vertically, folding aside like hinged panels. Beneath sits a second, recessed set of mechanical lenses packed tight like night-goggles. They click and whir as they light up, cycling through thermal, low-light, and edge-detection modes.

**Effect:** You receive a bonus die when darkness causes negative modifiers to see things.

### Nausea Pulse

Two compact emitter-arms rest flush against your collarbones, shaped like jointed struts. When triggered they rise and pivot forward, releasing a directed microwave or ultrasonic blast that scrambles balance and turns stomachs. Victims stagger, clutching their guts or fighting vertigo, while the emitters glow and vent heat.

**Effect:** Enemies in range roll a penalty die on all their Attack Rolls for the first round following its use. This ability can be triggered once a day, or again by spending a Glitch Point.

### Polygraph Visor

A heavy, full-face visor packed with thermal sensors, pulse analyzers, and eye-dilation trackers. It overlays micro-readouts of stress and hesitation directly into your vision, making lies glow as bright as warning lights.

**Effect:** Roll a bonus die when attempting to discern if someone is lying or deceiving you.

### Precision Fingers

Custom cybernetic hands and slender forearms built for subtlety. Ultra-fine servos, pressure-sensitive pads, and retractable tools give you the grace to pick pockets, palm cards, or assemble delicate devices without a sound. The look is unmistakable—long, jointed digits that move with eerie fluidity.

**Effect:** Roll a bonus die when performing tasks that require fine manipulation (picking pockets, crafting, juggling, card tricks, etc.).



### Reforged Persona

Your personality has been torn down and rebuilt by machine logic. Weeks of interface with AGI systems left behind a framework of behavioral implants that quietly overwrite your instincts. People sense something unnervingly right about you, whether soothing or commanding, it bends the room around your presence.

**Effect:** Add +1 to your Appeal attribute. Your maximum Appeal is 6 rather than 5, and your maximum starting Appeal is 4 rather than 3.

### Reflex Booster Implant

A spinal and cortical implant tuned to accelerate neural transmission, fitted with micro-capacitors that discharge bursts of energy through your nervous system. Small signal nodes run the length of your spine and pulse faintly when active, proof that your body now moves faster than thought.

**Effect:** Receive a bonus die to your Priority Rolls.

### Reflex Lattice

Your nervous system has been rebuilt with optic-fiber nerve replacements running along your spine and limbs. Each impulse travels with light-speed clarity, stripping out lag and noise, while reinforced joints and myomer-driven muscles follow through with flawless precision.

**Effect:** Add +1 to your Agility attribute. Your maximum Agility is 6 rather than 5, and your maximum starting Agility is 4 rather than 3.

### Rogue AI Pact

At some point you made contact with a self-aware rogue AI. Whether through mutual respect, curiosity, or some forgotten favor, it treats you as one of its own. Your implants are keyed to its encrypted channels, and sometimes fragments of its presence whisper advice in your mind.

**Effect:** Roll a bonus die when dealing with rogue or independent AIs. They treat you like an ally rather than a threat.

### Sculpted Perfection

High-end facial reconstruction and subdermal sculpting, enhanced pheromone emitters, and posture-assist joints create a striking appearance.

**Effect:** Roll a bonus die in situations where good looks might be important.

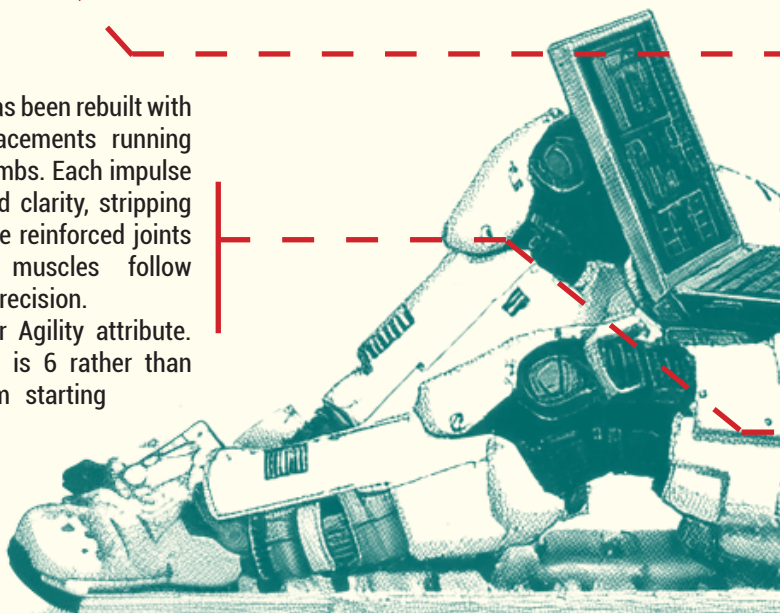

### Sensory Augment Array

Auditory implants, micro-haptic whisker-pads, and olfactory amplifiers combine to paint a detailed picture of your surroundings even in absolute darkness. You fight by sound, scent, and subtle air pressure changes rather than sight.

**Effect:** You ignore all penalties applied to fighting in darkness.

### Shoulder Shade

You carry a crude parasitic module: a small secondary head-unit that folds from your shoulder. It has no face, just sensor clusters and a whisper-voice tuned to underworld chatter. Some call it a ghost-partner, others a gutter-AI. It leaks black market tips, warns you of shady moves, and gives you the edge in the back alleys.

**Effect:** Roll a bonus die when dealing with street scum, gangs, or underworld activity, or when trailing and noticing things in a city environment.

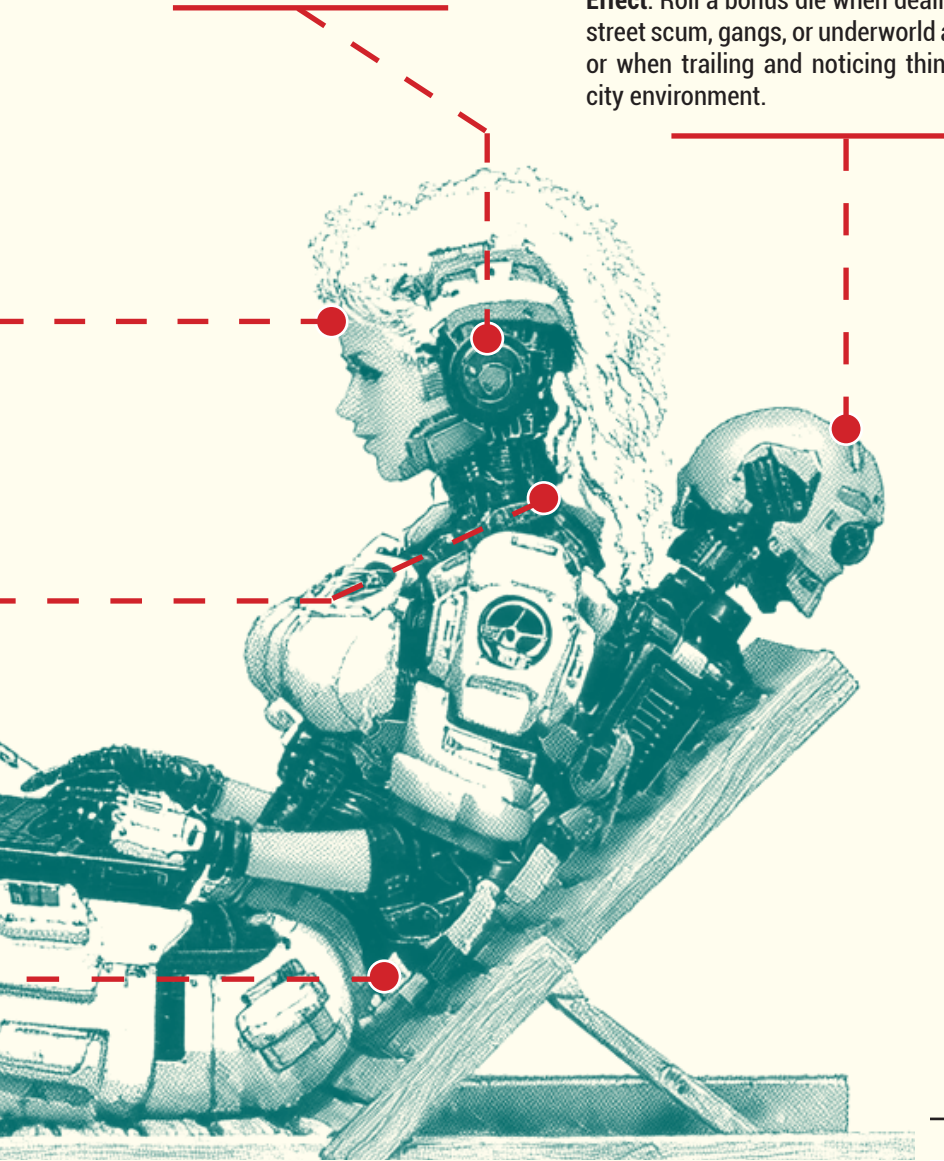

### Tactical Uplink

A rack of sensor stalks and twitching antennae juts from your shoulders and skull, constantly scanning and parsing the battlefield. Master-tactician software overlays enemy positions and weak points, transmitting firing solutions and angles directly into your allies' comms and visors.

**Effect:** Once per day you may trigger a tactical burst. All companions linked to your uplink gain a bonus die to their Attack Rolls for one round. This can be done again by spending a Glitch Point.

### Tavern Rat

A mix of lived experience and a cybernetic graft. You know how to work a crowded bar, keep drinks flowing, and coax loose tongues into spilling secrets. Meanwhile, a reinforced synthetic liver filters out toxins and keeps you upright long after everyone else has collapsed.

**Effect:** Roll a bonus die to gain information, make contacts, or acquire goods and services whilst in a tavern. You are also resilient to the effects of alcohol.

### Terror Sculpt

Instead of symmetry and allure, your cybernetics are sculpted into a nightmare. Reinforced faceplates shaped like skulls, demon visages, or jagged predator maws, with horns, spikes, and glowing eyes as desired. Designed by specialists who understand intimidation as an art form. When you enter a room, people notice—and many flinch.

**Effect:** Roll a bonus die whenever you are trying to force somebody to give you information or do something they don't want to do.



### Utility Armature

Your forearm or hand conceals a built-in suite of professional tools. Miniature blades, welders, drivers, magnifiers, or lockpicks snap out on demand depending on your career. The configuration is unmistakably cybernetic—a patchwork of seams and slots running down the arm, always ready to unfold into what you need.

**Effect:** Roll a bonus die when attempting any actions where specialized tools from your trade or craft would be beneficial.

### Vent Ports

Your back is studded with mechanical vents that snap open when you dive into hostile systems. Steam and heat pour out as hidden fans and coolant lines strain to keep you from burning up. The rush lets you push beyond safe hacking limits, but the overclock scars both body and mind.

**Effect:** You gain two extra Exploit Points. However, you must also take an extra flaw.

### Weakpoint Scanner

At rest, your face looks almost normal apart from a few ridges. When the system engages, a quarter of your face splits open with mechanical precision, revealing a specialized visor assembly that extends outward. Thin scanners sweep and pulse across a target, mapping welds, seam-lines, heat leaks, and joint tolerances to reveal likely weak points. The visor hums as it highlights exactly where a shot will deal the most damage.

**Effect:** When using ranged weapons (not thrown), you may add a flat +2 bonus to damage.

### Vehicle Integration Rig

Neural co-processors, spinal jacks, and direct-link ports extend your consciousness into a chosen vehicle type—ship, rover, or mount-equivalent. Reaction loops blur, letting you feel the machine as though it were part of your body.

**Effect:** When you pick this boon, choose one vehicle type. Roll a bonus die when driving or performing non-combat physical activities while operating that vehicle.

### Whisper Frame

Your limbs are rebuilt with padded feet, smoothed joints, and myomer fibers in place of noisy servos. Every step is softened, every motion damped. Plates fit snug without rattle, pistons hum at a whisper, and the usual cybernetic clatter is stripped away.

**Effect:** Roll a bonus die where stealth is important.

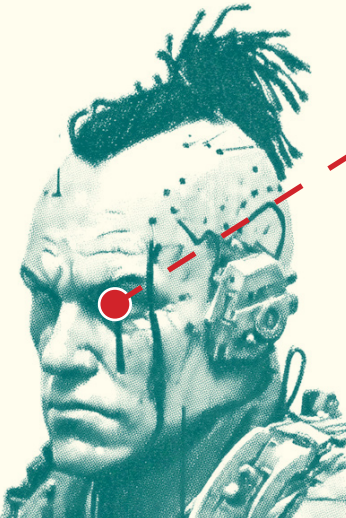

## Flaws

### Absent-Minded

While you are not necessarily stupid, you have difficulty keeping track of appointments, people's names, items on lists, and various other memory-based tasks. This means that sometimes the GM will spring things on you that your character forgot.

### All Thumbs

You take a penalty die when picking locks, firing guns, or when doing fine work.

### Arrogant

Roll a penalty die when dealing with workers or foreigners, where your arrogance might annoy or offend them. This flaw is especially common amongst the rich.

### Braggart

You have a very high opinion of yourself and feel the need to share it with the world. You often take credit for things that you never did, and make those accomplishments you did achieve seem so much grander with each retelling, often disregarding the role anyone else played in the story.

### Can't Lie

Whether it is simple nervousness or a strong code of honour, you are terrible at lying. You get a penalty die whenever you try to deceive, tell half-truths, or conceal something that you know when you are asked about it directly. You'd much rather say, "I'm not going to tell you," than "I don't know what you are talking about."

### City Dweller

You aren't happy in the great outdoors. You take a penalty die in situations to do with wilderness survival.

### Combat Paralysis

When swords are drawn, you tend to freeze up and act with uncertainty. Roll a d3. This is the number of rounds that you freeze, during which you can only take defensive actions.

### Country Bumpkin

The big city is a confusing and heartless place for the new arrival. You take a penalty die in situations to do with urban survival.

### Cowardly

This is not a very common flaw for a Hero, but you have a great deal of difficulty resisting when the effects of fear take hold of you. Roll a penalty die to any rolls to resist the effects of fear or intimidation. In addition, you try to avoid any form of conflict, if at all possible.

### Cravings

You are addicted to something and require it every day to function fully. Whenever you go more than a day without it, you have a penalty die on all rolls.

### Cursed

Fortune have forsaken you or you are just plain unlucky. You begin with -1 Glitch Point. For some reason, bad things always seem to happen to you.



**Delicate**

You have a small or slender build. Deduct two from your lifeblood total.

**Distinctive Appearance:**

There is something about the way you look that sticks in men's minds. Perhaps you have a very memorable scar or tattoo. Maybe you were born with six fingers on your left hand. Whatever it is, you have some superficial characteristic that causes you to stand out. You gain a penalty die whenever you try to disguise yourself or maintain a low profile. If you are also Hunted (see below), bounty hunters and spies are twice as likely to spot you on entering and leaving a city.

**Distrust of hackers/scientists**

When dealing with hackers and scientist, you take a penalty die.

**Distrust of Strangers**

You always doubt the honesty and reliability of people you don't know. This is mainly role-played – you will watch them closely in case they are tricking you, you'll remain tight-lipped in their presence and you'll begrudgingly carry out menial orders or requests. This will definitely lead to heightened tension in certain situations.

**Drunkard**

Roll a die when you are required to do something important for the rest of your companions. If a '1' comes up, you are drunk and unable to do anything until sobered up.

**Elderly**

Your character is not as young as he used to be. If he has not had a decent amount of rest each day, he will begin to slow and tire. Use an extra penalty die for any physical action if pushed too hard without rest. Other opportunities for good role-play will undoubtedly come out of this flaw.

**Fear of ...**

There is something that you have a great and irrational fear of. Roll a penalty die in the presence of (or when confronted by) your phobia. Some possible fears include: fear of fire, reptiles, spiders, heights, crowds, death, the dark, closed spaces, flying, etc.

**Feels the Cold**

You are especially susceptible to the cold. You take a penalty die for any tasks undertaken in a cold environment.

**Feels the Heat**

You are especially susceptible to heat. You take a penalty die for any tasks that you undertake in a hot or desert environment.

**Greed**

You cannot resist any chance to make money. If money is to be made, your judgement goes out of the window. You take a penalty die whenever tempted by the offer of cash.

**Gullible**

You believe the most outrageous lies. Roll a penalty die when being persuaded something is a good idea when it isn't.



### Hot-Headed

Your anger often gets the better of you, and you are likely to fly off the handle at the slightest insult or imagined insult. You get a penalty die to any rolls when trying to suppress your anger and act rationally, such as not making a scene at a royal ball when insulted, or trying to ignore an enemy's taunt. Your anger can also get you into brawls, or worse.

### Hunted

Perhaps you are wanted by the authorities, or have offended some powerful rich or bandit captain. Regardless of whom, you constantly have to evade agents intent on capturing or even killing you. Roll a d6 whenever you enter a new city. On a 1, agents of your enemy (or your enemy himself, if you choose) will spot you and make your life unpleasant.

### Illiterate

You cannot read or write, and you cannot choose a career with literacy as a requirement.

### Infamous

You are well known for some wicked deed in your past. Irrespective of whether the allegations are true or not, or whether you had a good reason to do what you did, this bad reputation precedes you wherever you go. You get a penalty die in social situations when making first impressions, and continue to receive the penalty until you earn a person's trust.

### Landlubber

You take a penalty die on activities whilst at low or zero gravity environments.

### Lumbering

You are unsteady on your feet. You take a penalty die when balance is important – for example, crossing a narrow bridge or standing on a building ledge.

### Lustful

You find it hard to resist the charms of the opposite sex, and you get a penalty die to any rolls to avoid succumbing to a pretty or handsome face.

### Morgazzon's Curse

You are mad. Work with the GM to determine how this manifests itself.

### Missing Eye or Ear

You take a penalty die whenever the GM feels it is appropriate to the situation.

### Missing Limb

You take a penalty die whenever the GM feels the situation is appropriate.

### Mute

You are unable to talk, so always roll a penalty die in social situations to make yourself understood.

### Non-Combatant

You are not a warrior – your skills lie elsewhere. You have only two points to spend on combat abilities instead of four, but begin with six points for careers instead of four. In addition to this, it costs you twice as many advancement points to increase combat abilities.



**Obsession**

There is something with which you are completely obsessed. It could be a fascination with a certain pursuit, person, or thing. You spend a great deal of time and money on this obsession. Whenever you are in the presence of the object of your obsession, you have a penalty die on all rolls that require you to ignore it. Sometimes your obsession can get you into a lot of trouble.

**Poor Eyesight**

You take a penalty die when trying to observe or spot something.

**Poor Hearing**

Whenever you make a check to perceive something using your hearing, you take a penalty die.

**Poor Recovery**

You have a poor constitution. You require medical attention to restore lost lifeblood, and recover nothing from normal rest.

**Taciturn**

Your character is ridiculously tightlipped. It's a rare day on which he uses a sentence of more than three words, and it's virtually unheard of for him to initiate conversation. His extreme reluctance to speak unfortunately means he never volunteers information without being asked. Take a penalty die in social situations.

**Ugly & Brutish**

You are unattractive. Take a penalty die in situations where your looks are important.

**Unprepared**

You are not aware of what's going on around you and are slow to react to danger. Add a penalty die for Priority Rolls.

**Unsettling**

Something about you isn't quite right – the way you look or smell or speak. Even animals shy away from you. Take a penalty die in social situations or when dealing with animals.

**Untrustworthy**

You take a penalty die when the situation calls for someone to believe or trust you.

**Zealot**

This is a flaw far more common amongst villains than Heroes. There are many willing to die for their faith, but a zealot would kill for it. You get a penalty die whenever you must be civil to a non-believer.



## Firearms of the Current Era

Conventional brass cartridges are obsolete. Powder-based firearms are rare now for logistical reasons. Instead people rely on sophisticated electromagnetic coil guns that use micro-cutters to shave special metal bars into projectiles on demand. Those metal bars are compact, easy to manufacture and transport, and a single carrier can hold far more "ammo" than an equivalent number of cartridges. The biggest limiting factor for a shooter is heat management – fire too many rounds too quickly and the weapon will overheat, warp, or fail.

- Holdout guns have a bonus (or double bonus) dice to be hidden. Visible guns create social problems and doesn't help make friends. The bigger, the more problems you will have. Also, Holdout weapons can be used in close combat without penalty.
- Fragile weapons break on a fumble.
- Stun weapons force the target to roll body vs Stun value or fall prone three rounds or makes another save.
- Weapons with overheat (OH) can shoot faster or on autofire, at the cost of heat. Damage changes to shown value, and then roll 1d6 vs OH number, if equal or lower, weapons overheat until an action to cool it is used or 3 rounds pass.

WEAPON	RANGE	DAMAGE	OH	AVAILABILITY	NOTES
Knife	10	d6L	-	Easy	1h, concealeable
Axe	10	d6	-	Normal	1h
Baton	-	d6	-	Easy	1h
Big Blade	-	d6 or d6H	-	Normal	1h or 2h
Mono-sword	-	2d6	-	Tough	2h, fragile
Pocket pistol	10	d6L	-	Hard	1h, holdout(2)
Handgun	15	d6	d6H : 3	Hard	1h, holdout
Sub-machine gun	30	d6	2d6L : 3	Tough	2h
Assault rifle	50	d6H	2d6 : 3	Tough	2h
Sniper rifle	90	2d6	-	Tough	2h
Grenade	5	d6+2	-		
Flamethrower	5	d6H	-		
Taser	2	1	-		Stun (11)
Tranquilizer pistol	10	1	-		
Tranquiliser rifle	30	2	-		



# Armors

## NO ARMOR

### Normal Clothing / None

Station fashion is loud and impractical: oversized ponchos, layered capes, draped coats that flare and drift dramatically in Og. The wealthy and the stylish flaunt these looks, fastening them with cords and velcro tabs to keep the fabric from tangling. Practical types prefer sleek form-fitting gear—athletic skins, techweave bodysuits—that never snag. The difference is more than fashion; it's a statement of identity. No armor, no penalties.

### Skin Suit

A second-skin of elastic polymers and sponge-mesh that clings to every contour. Every detail of the body is visible through its glossy finish, making modesty optional. The suit hangs with a soft hood at the neck; pull it up, pair it with the detachable mask and gloves (usually clipped to the belt), and it seals for short-term vacuum survival. It's an iconic spacer garment: worn beneath clothes for practicality, or boldly on its own by those hardened to the void—or simply unashamed. It offers no micrometeoroid or radiation protection, but it might save your life in a breach.

**Effects:** *Counts as no armor (no Exploit penalty). Can be sealed for short-term vacuum survival (GM sets duration).*

## LIGHT ARMOR

*(Protection 1d6–3 • 1 Exploit penalty)*

### Space Suit

Layered insulation and micrometeoroid mesh with life support, comms, and thrusters. Tough against pin-speck debris, not against bullets or blades. "Combat EVA" fails at the joints: every bearing and seal is a weak point, and adding plates wrecks mobility and pressure integrity.

**Effects:** *–1 Agility, –2 Social. Vacuum-sealed, maneuvering thrusters, oxygen tank, comm kit.*

### Concealed Vest / Body Mesh

Aramid/ultra-high-molecular-weight fibers under clothing. Stops common handguns; rifle fire overmatches.

**Effects:** *–1 Agility. Concealable.*

### Light Armored Jacket & Pants

Reinforced civilian wear with ceramic inserts. Passes for workwear or biker gear; still obvious up close.

**Effects:** *–1 Social.*

### Industrial EVA Layer

A work-skin for station exterior jobs—radiation and micrometeoroid resistant, not a full EVA suit. With gloves clipped at the belt, fixed hood, and emergency mask, it can be sealed for short vacuum stints.

**Effects:** *–1 Agility, –1 Social. Short-duration vacuum seal.*

### MEDIUM ARMOR

(Protection 1d6-2 • 2 Exploit penalty)

#### Armorjack

Composite weave with rifle-rated ceramic plates. Private security standard.

**Effects:** -1 Agility, -2 Social.

#### Riot Armor

Padded suit with rigid joint plates and helmet. Built to disperse blunt force and crowd threats.

**Effects:** -1 Agility, -3 Social. Counts as one category higher vs. Brawling damage (treat Protection as Heavy vs. unarmed/club effects).

#### Industrial Exosuit Frame

Powered assist skeleton over light armor. Meant for cargo, not fighting; the gait is heavy, the lift is immense.

**Effects:** -2 Social. Gain a bonus die on Strength Feat tests (non-combat only).

### HEAVY ARMOR

(Protection 1d6-1 • 3 Exploit penalty)

#### Heavy Armorjack

Full ceramic plates, trauma pads, and sealed helmet rig. Military-grade presence.

**Effects:** -2 Agility, -3 Social.

#### Security Exoskeleton

Combat-adapted exo over plates. Carries big guns and heavy kits, but grace is gone.

**Effects:** -2 Agility, -2 Social. Gain a bonus die on Strength Feat tests (non-combat). Suffer a penalty die on athletic/acrobatic tests.

#### Hard-Shell EVA Suit (Prototype)

Rigid exosuit for limited EVA combat. Bearings instead of fabric joints; sealed, armored, and wildly impractical. Exists mostly in labs and corporate vaults.

**Effects:** -3 Agility, -4 Social. Vacuum-sealed, oxygen, thrusters. Rare and cumbersome.



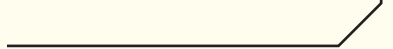
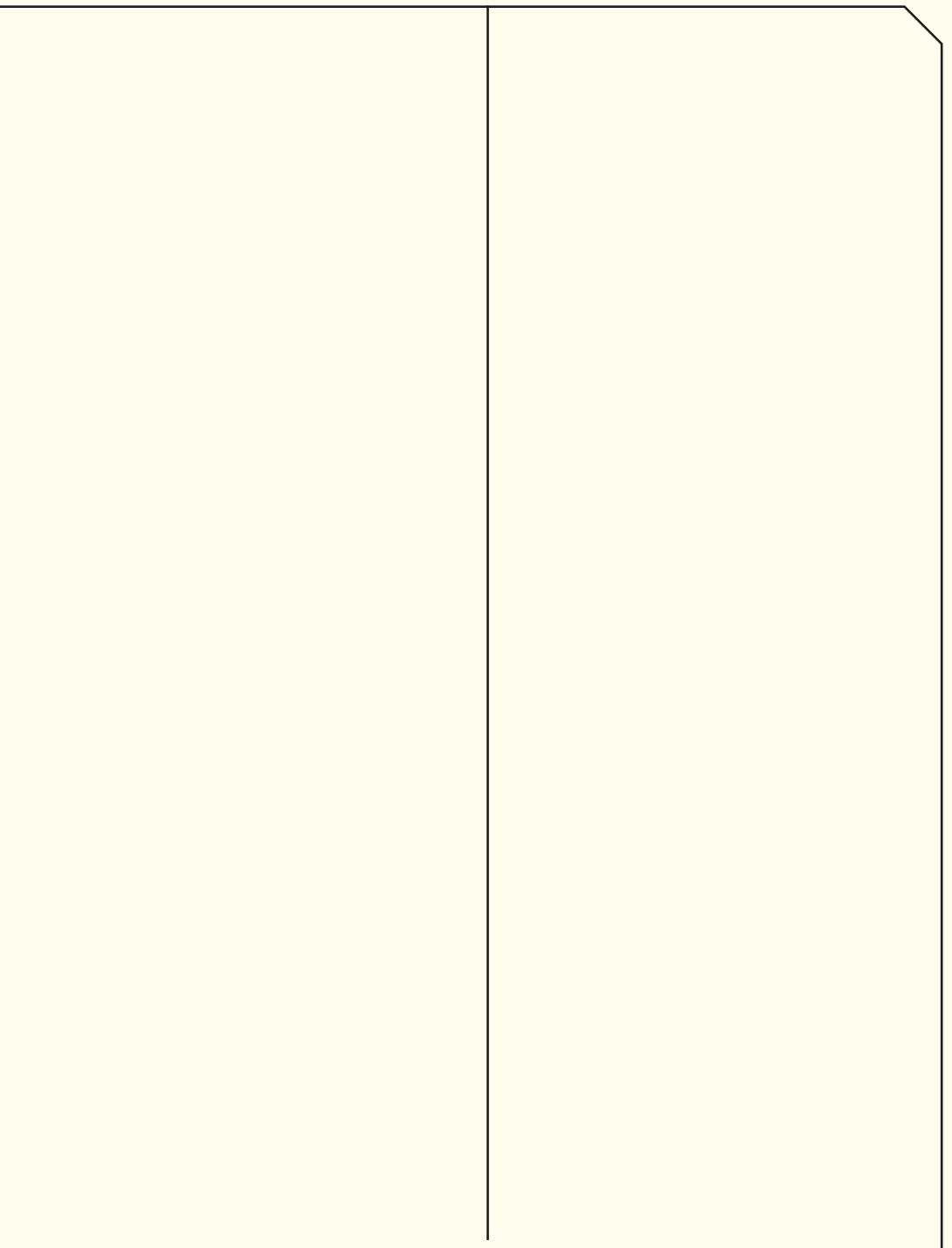
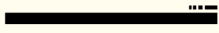

# WORLD INFO

## *General View*

Humanity has expanded into space, but not far—we're still confined to the Solar System. This is only a few decades into the future, not millennia. Our stations are rudimentary, and artificial gravity does not exist. Smaller stations are completely weightless, with only closed centrifugal sleeping pods to help people rest and maintain their bodies. Larger stations use rotating rings to create centrifugal force, though none are close to Earth-level gravity. A full 1g would require a massive ring, kilometers in diameter, which we can't yet build. The largest stations rotate at about 3 to 4 revolutions per minute, producing a comfortable—if slightly weaker—gravity.

Humanity's main settlements cluster around the Lagrange Points, which make orbital logistics easier. There are also colonies on Mars and on some of the moons of the outer planets. Most of these outposts exist to extract resources—mining colonies that fuel civilization's endless appetite for raw materials.

Beyond these hubs lies the asteroid belt, stretching between Mars and Jupiter. Here lies the underworld: pirate enclaves, smuggling ports, and criminal strongholds. This is where outlaws thrive—and where the player characters, the bandits, make their living.

## *Cybernetics*

One of the greatest technological breakthroughs of this era is cybernetics. Humanity has finally breached the barrier between silicon and synapse—chips and brains can now speak the same language. This ushered in an age of implants and prosthetics that allow people to survive in the black void.

Cloning and vat-grown organs remain out of reach, but mechanical replacements are common. Prosthetic arms that look like they were torn from a steampunk sketch are closer to the norm than sleek, fleshlike limbs. The technology is powerful and widespread, but only the most expensive or experimental models can truly pass for natural flesh.

For most, appearances hardly matter anymore. Society has grown accustomed to reshaped skulls, bulbous cybernetic eyes, glowing visors, and limbs that make no attempt to mimic human anatomy. Cybernetics are tools first, identities second. Function outweighs form in the void.

## *Tools of War*

One of the greatest technological Weapons have, oddly, regressed in some ways. Powder-based firearms are rare now for logistical reasons. Instead people rely on sophisticated electromagnetic coil guns that use micro-cutters to shave special metal bars into projectiles on demand. Those metal bars are compact, easy to manufacture and transport, and a single carrier can hold far more “ammo” than an equivalent number of cartridges.



The biggest limiting factor for a shooter is heat management – fire too many rounds too quickly and the weapon will overheat, warp, or fail.

At first glance coil guns seem superior: cheap, easy to resupply, and energy-efficient to store in bulk. In practice they have trade-offs. Coil weapons tend to be less accurate and have shorter effective ranges than legacy lead rounds. You also lose the variety of specialized ammunition (explosive, flechette, etc.) that conventional cartridges can deliver without complex engineering. Still, logistics win: in the cramped corridors and habitats of the system, range isn't the top priority, and being able to carry mountains of raw metal rods is a major advantage.

Melee weapons, meanwhile, are as brutal and inventive as ever. Monoblade katanas, heated knives, jet-assisted hammers and improvised hybrids – the asteroid engineers make things that are ugly, efficient, and deadly.

## *Points of Interest*

### **LAGRANGE POINTS**

#### **L1 – The Shield**

Closest to the Sun–Earth line. A fortress and gateway: solar observatories, military satellites, defense contractors. Think checkpoints, customs, and military yards. All long-haul routes brush past L1, so smugglers always try to slip through or around its gaze.

#### **L2 – The Shadow Bazaar**

Hidden behind Earth, but economically

vital. It's the back door for traffic to Mars, Luna, and the Belt. Why isn't it crushed by "the authorities"? Because it's useful: governments and megacorps quietly tolerate L2 as a den of smugglers, fixers, and shadow bankers. Everyone pretends not to see it, because everyone benefits from the dirty work that happens here.

#### **L3 – The Phantom Exchange**

On the far side of the Sun. Officially a hub for long-haul comm relays and trade depots; unofficially, it attracts the eccentric, the visionary, and the cultist. The central city is strange but functional – deals get done, ships get fueled. The real fringe cults and breakaway societies are based far from the hub, in hidden habitats and free-floating settlements. The city acts as their embassy and market.

#### **L4 – The Guilds**

A stable point with heavy industry. Refineries, shipyards, assembly lines. Ore from the Belt and ice from the moons flow here to be turned into fuel, components, and hulls. Trade unions, corporate cartels, and organized crime all fight for control. High traffic, high stakes.

#### **L5 – The Carnival Frontier**

The other stable point. Chaotic, colorful, and overflowing with migrants, itinerant workers, and freeports. Think Kowloon Walled City in space. Nightclubs, betting houses, zero-g circuses, all wrapped around repair docks and black markets. It's a pressure valve: people go to L5 to escape, spend, and vanish.



## OTHER COLONIES

### Mars – The Red Frontier

Dome-cities clinging to canyons and polar caps. Dust storms, oxygen riots, endless corporate spin about “terraforming any year now.” Hard folk, always bargaining, always on edge.

### Europa – The Veiled Ocean

Ice-crust research colonies drilling for life in the deep saltwater sea. Claustrophobic tunnels, corporate secrecy, whispered stories of things moving under the ice. No one stays sane here long.

### Titan – The Haze

Golden methane skies, strange seas, and floating platforms harvesting hydrocarbons. Sluggish, dreamlike culture. Rumors of drugs distilled from Titan's haze that warp human perception.

### Asteroid Belt – The Black Market

Endless scattered rocks, each hiding something: pirate strongholds, fugitive enclaves, secret shipyards. Law has no purchase here; only reputation and guns matter.

## *Who Rules*

### The Solar Accord

A shaky coalition of Earth governments, Mars colonies, and the biggest corporations. Formed to prevent resource wars and keep trade flowing.

It “authorizes” patrols, tariffs, and space law courts – but each faction bends the rules.

Enforcement is done by the Interplanetary Patrol, a mix of military detachments and corporate security under a single banner. They're stretched thin, underpaid, and corruptible.

### Local Authorities

Mars has its own planetary council, nominally under the Accord but fiercely independent.

Lagrange Points each have their own city councils or syndicates – half government, half corporate boards.

The Belt is technically under Accord jurisdiction but in practice self-governed by mining cartels, outlaw clans, and pirate kings.

### Why pirates and smugglers thrive

Traffic is too much to police: hundreds of shipments, thousands of small freighters.

The Accord relies on smugglers to move embargoed goods, off-the-books tech, or deniable cargo.

Pirates flourish where patrols are rare – and where local bosses look the other way in exchange for bribes.



## *Travel In The System*

Getting around the Solar System isn't instant, but it isn't a lifetime either. Journeys are measured in weeks to months, not days or decades. The GM decides the exact timing, fast or slow as the story needs.

### **Haulers**

Bulk freighters that keep the colonies alive. They run on nuclear thermal rockets or ion drives: efficient, steady, and slow. Travel stretches from a few months to nearly a year. Some have a small rotating torus for sleeping, but most of the ship is weightless. Life aboard means recycled air that smells faintly metallic, algae-based meal packs, and coveralls stained from constant repairs. Crews are practical, patient, and usually half-asleep from long shifts.

### **Gunships**

Patrol craft with nuclear thermal engines and limited fusion boosters. Built for short bursts and short ranges, they guard Lagrange Points and convoy routes. There's no gravity, and living space is cramped between reactor shielding and weapon racks. Crews eat heat-sealed ration bricks at their consoles and wear sweat-wicking liners under their vacuum suits – ready to scramble at a moment's notice. The ship hums with reactor noise and smells of machine oil.

### **Cutters**

Compact, fast couriers with fusion drives. They cross short routes in weeks, long ones in a few months. They can't carry much cargo, and there's no gravity at all – just straps, tie-downs, and narrow

bunks along the hull. Food is nutrient paste tubes and vacuum-packed snacks, clothing is layered thermal gear against uneven heating, and everything rattles when the drive pushes hard. Cutters are noisy, jittery, and always feel a little unsafe – which is why smugglers, hunters, and desperate couriers love them.

### **Addendum: The Bandit's Cutter**

Official cutters are spartan, but smugglers and pirates rarely leave them bare. Some weld in centrifugal sleeping pods or improvised spinning drum cabins to give the crew a few hours of comfort. Kitchens might sprout illegally tapped hydroponic racks or black-market protein printers, turning the usual nutrient sludge into something that smells like stew. Cabins get lined with rugs, insulation foam, even old ship banners to deaden the rattle of the drive. These modifications eat up precious cargo space and power, but crews swear it keeps them sane on long runs – and nothing boosts morale like real coffee brewed in microgravity.

